



Maldives Marketing and Public Relations Corporations
Republic of Maldives

REQUEST FOR PROPOSALS (RFP)
TO DESIGN AND CONSTRUCT THE MALDIVES STAND AT FESPO 2023

27th December 2022

Section 1 - Instruction to Tenderers		
1.	General	
1.1	Announcement Number:	(IUL)MMPRC-PRO/MMPRC/2022/65
1.2	Announcement Date:	27 th December 2022
1.3	Project:	TO DESIGN AND CONSTRUCT THE MALDIVES STAND AT FESPO 2023
1.4	Registration Deadline (Date & Time)	4 th January 2023, via E-Mail, before 1000 hours (MALDIVES LOCAL TIME) procurement@visitmaldives.com
1.5	Submission Deadline (Date & Time)	10 th January 2023 via E-Mail, before 1400 hours (MALDIVES LOCAL TIME) tender303@visitmaldives.com
1.6	Bid Addressed to:	Mr. Hassan Shaheel General Manager, Procurement Maldives Marketing and Public Relations Corporation H. Zonaria, 2nd Floor, Boduthakurufaanu Magu, Male' Republic of Maldives Email: tender303@visitmaldives.com
1.7	Fair/ Event Details	
	Name of the Fair	FESPO 2023
	Venue	Zurich Exhibition Center
	Stand Size	Stand Area: 64sqm Stand dimension is 8.0x8.0 (refer to user manual) Hall: 06 Stand Number: 6.024 (Four (04) sides open) (Floorplan attached)
	Dates of the Fair	02-05 February 2023

2.	Procedure of Tendering
2.1	<p>Eligible Tenderers:</p> <p>a) A Tenderer may be a sole proprietor, private entity, a registered company or government-owned entity or any combination of them in the form of a joint venture, under an existing agreement, or with the intent to constitute a legally enforceable joint venture.</p> <p>b) The Tenderer must provide an English Translation of the company registration certificate, if the original company registration certificate is in any other language., along with the original registration Certificate. And this translation should be signed by authorized signatory.</p>
2.2	<p>Amendments to Tender Documents:</p> <p>(a) At any time prior to the deadline for submission of Tenders, MMPRC may amend the Tendering Document by issuing addenda.</p> <p>(b) Any addendum issued shall be part of the Tendering Document and shall be communicated in writing to all who have obtained the Tendering Document from MMPRC</p> <p>(c) To give prospective Tenderers reasonable time in which to take an addendum into account in preparing their Tenders, the Employer may, at its discretion, extend the deadline for the submission of Tenders</p>
2.3	<p>Registration of Tenderers:</p> <p>To register please email with the following information to procurement@visitmaldives.com by 4th January 2023 before 1000 hrs. (Maldives Local Time).</p> <p>(Only registered parties shall be eligible to submit the proposal.)</p> <p>Company name:</p> <p>Contact person name:</p> <p>Email:</p>
2.4	<p>Pre-bid meeting / Info Session: 4th January 2023 at 1500hrs (Maldives Local Time).</p> <p>Meeting link (Google Meet) will be shared via email with the registered tenderers only.</p>
2.5	<p>Clarifications of Bidding document, project, scope of works:</p> <p>Monday, 9th January 2023 before 1200hrs (Maldives Local Time).</p> <p>Email: procurement@visitmaldives.com</p> <p>CC to shaheel@visitmaldives.com</p>

2.6	<p>Submission of Tenders:</p> <p>Tenders must be received by MMPRC at the address or by email and no later than the date and time mentioned below.</p> <p>Venue: Maldives Marketing & Public Relations Corporation, 2nd Floor, H. Zonaria, Male'</p> <p>Date: 10th January 2023</p> <p>Time: Before 1400hrs (Maldives local time)</p> <p>Email: tender303@visitmaldives.com</p>
2.7	<p>Unless specifically stated otherwise in this RFP, all queries and communications in respect to the RFP or the tender process shall be addressed by any Respondent to MMPRC, by e-mail or in writing.</p>
2.8	<p>This RFP and all the entities participating in the Bid Process shall be governed by the laws of Maldives, without having regard to its principles of conflict of laws. Only the courts in Maldives shall have exclusive jurisdiction to entertain, hold trial, and adjudicate upon any dispute in relation to the RFP, Bid Process, or any other aspect in relation thereto.</p>
2.9	<p>Clear scanned documents must be provided. If it's not possible to read the scanned documents, the evaluation committee has the discretion to disqualify.</p>
3.	Preparation of Tenders
3.1	<p>Each Respondent shall submit a single proposal (options may be submitted).</p>
3.2	<p>Cost of Tendering:</p> <p>The Tenderer shall bear all costs associated with the preparation and submission of its Tender, and MMPRC shall in no case be responsible or liable for those costs, regardless of the conduct or outcome of the tendering process.</p>
3.3	<p>Language of Tender:</p> <p>The Tender, as well as all correspondence and documents relating to the Tender exchanged by the Tenderer and MMPRC, shall be written in English. Supporting documents and printed literature that are part of the Tender may be in another language provided they are accompanied by an accurate translation of the relevant passages in English, in which case, for purposes of interpretation of the Tender, such translation shall govern.</p>
3.4	<p>Measurements:</p> <p>All measurements shall be expressed in units of the metric system.</p>

3.5	<p>Documents Comprising the Tender:</p> <p>3.5.1 Cover Letter as per section 4 indicating authorized signatory to sign the tender documents.</p> <ul style="list-style-type: none">- The Tender proposal <u>will be disqualified</u> if the document is not submitted with the Tender.- The name of the authorized person, signature and stamp of the company should be included. <p>3.5.2 Quotation</p> <ul style="list-style-type: none">- Tender proposal <u>will be disqualified</u> if the document is not submitted with the tender.- Contract Price shall include detailed cost breakdown of designing and construction of the stand.- All calculations and costing should be in US Dollars. <p>3.5.3 Copy of registration Certificate of Sole proprietorship / Partnership / Company / Corporative Society</p> <ul style="list-style-type: none">- Tender proposal <u>will not be eligible</u> if the document is not submitted with the Tender.- If certificates are in other language, English translation should be provided along with copy of original certificate and this translation should be signed by authorized signatory. <p>3.5.4 Profile of the Tenderer</p> <ul style="list-style-type: none">- Marks <u>will be deducted</u> if the document is not submitted or is not submitted as per the RFP.- Profile of the tenderer should include the following;<ul style="list-style-type: none">• The organizational structure• Number of years in operation• Services offered by the company• Proposed team for this project <p>3.5.5 Past Experience</p> <ul style="list-style-type: none">- Tender Proposal <u>will be disqualified</u> if the documents as per RFP is not submitted.
-----	---

- Must be similar projects undertaken within the past 5 years from the date of this announcement.
- The Letter or email should contain the contact details for further reference.
- The letters or email should clearly mention the type of work undertaken for the clients.
- Work order forms, agreements or award letters will not be considered as past experience letters.
- Pictures of previous design and construction works shall be provided along with reference letters of projects within the last 5 years.
- The pictures provided should be of the same reference letters or emails submitted and should state the name of the firm and year
- Past experience letter will only be accepted as complete if the supporting images and details are provided.

3.5.6 Proof of financial capability

- Tender proposal will be disqualified if the document is not submitted with the tender or if the bidder do not have 20 percent of the quoted price in their bank account.
 - Each Tenderer/Respondent should submit proof of financial capability by submitting the following documents.
 - a) Bank reference letter. This letter should be in bank letterhead with authorized signature of the bank or bank stamp. The letter should state that the 20% of the quoted price is available in their bank account.
- OR**
- b) Last 3 months' bank statement on the bank letterhead with the authorized signature of the bank or the bank stamp.
- If the letter or the bank statement is in other language, English translation should be provided along with copy of original letter or the bank statement and this translation should be signed by authorized signatory.

	<p>3.5.7 Proposed Stand design</p> <ul style="list-style-type: none"> - Tender proposal will be <u>disqualified</u> if the document is not submitted with the tender and <u>marks will be deducted</u> if the document is not as per the RFP. - The stand design must be with detailed layout marking each area and drawings from all angles (AERIAL, FRONT and SIDE VIEWS) as per the specification and scope provided by MMPRC in Section 3 of this RFP. - Each Tenderer shall mark in the detail drawing the measurements of counters, private meeting table area, storage and any other areas specified in the RFP.
<p>3.6</p>	<p>Period of Validity of Tender:</p> <p>(a) Tenders shall remain valid for 90 calendar days after the Tender submission deadline date prescribed by MMPRC. A Tender valid for a shorter period shall be rejected by MMPRC as nonresponsive.</p> <p>(b) In exceptional circumstances, prior to the expiration of the Tender validity period, MMPRC may request Tenderers to extend the period of validity of their Tenders. The request and the responses shall be made in writing.</p>
<p>3.7</p>	<p>Tender Security (If required): Not Applicable</p>
<p>3.8</p>	<p>Format of Signing of Tender:</p> <p>The Tenderer shall prepare one original of the documents comprising the Tender as described in Clause 3.5, and clearly mark it “Original”. Alternative Tenders, if permitted in accordance with clause 3.11, shall be clearly marked “Alternative”.</p>
<p>3.9</p>	<p>Budget</p> <p>The Tenderer must propose a contract price.</p> <p>The Contract Price may only be adjusted by the parties as per the terms and conditions of the Agreement.</p> <p>In case the payment for rigging/electricity or any other such advance payments to the organizers, it should be paid by the Selected Respondent/Contractor on behalf of MMPRC. The Selected Respondent/Contractor should submit the invoice along with the supporting</p>

	documents after which it will be reimbursed. These payments should be pre-approved by MMPRC.
3.10	<p>Taxes</p> <p>a) All Bidders shall quote the prices inclusive of Taxes</p>
3.11	<p>Alternative Tenders:</p> <p>It is permitted to submit Alternative Tenders.</p>
3.12	<p>Conflict of Interest:</p> <p>A Tenderer shall not have a conflict of interest. All Tenderers found to have a conflict of interest shall be disqualified. A Tenderer may be considered to have a conflict of interest with one or more parties in this tendering process, if:</p> <p>(a) they have a controlling partner in common; or</p> <p>(b) they receive or have received any direct or indirect subsidy from any of them; or</p> <p>(c) they have the same legal representative for purposes of this Tender; or</p> <p>(d) they have a relationship with each other, directly or through common third parties, that puts them in a position to have access to information about or influence on the Tender of another Tenderer, or influence the decisions of the Employer regarding this tendering process; or</p> <p>(e) a Tenderer participates in more than one Tender in this tendering process. Participation by a Tenderer in more than one Tender will result in the disqualification of all Tenders in which the party is involved. However, this does not limit the inclusion of the same subcontractor in more than one Tender; or</p> <p>(f) a Tenderer or any of its affiliates participated as a consultant in the preparation of the design or technical specifications of the contract that is the subject of the Tender; or</p> <p>(g) a Tenderer, or any of its affiliates has been hired (or is proposed to be hired) by MMPRC.</p>
3.13	The Tenderer shall not engage in corrupt or fraudulent practices in the preparation or lodgment of a Bid. The Tenderer shall not have any commercial mutual benefits with other Tenderer(s) submitting the Bids on the date of submission of the Bid.

3.14	<p>Authorization:</p> <p>The original and the Alternative Tender shall be signed by a person duly authorized to sign on behalf of the Tenderer. This authorization shall consist of a written confirmation and shall be attached to the Tender. The name and position held by each person signing the authorization must be typed or printed below the signature.</p>
4.	<p>Submission and Opening of Tenders</p>
4.1	<p>Deadline for Submission of Tenders:</p> <p>(a) Tenders must be received by MMPRC at the address or by email and no later than the date and time mentioned in clause 1.5 of this document.</p> <p>(b) MMPRC may, at its discretion, extend the deadline for the submission of Tenders by amending the Tendering Document, in which case all rights and obligations of the MMPRC and Tenderers previously subject to the deadline shall thereafter be subject to the deadline as extended.</p>
4.3	<p>Late Tender:</p> <p>MMPRC shall not consider any Tender that arrives after the deadline for submission of Tenders, in accordance with clause 1.5. Any Tender received by MMPRC after the deadline for submission of Tenders shall be declared late, rejected, and returned unopened to the Tenderer.</p>
4.4	<p>Withdrawal and Re-submission:</p> <p>The Respondents may withdraw at any time before the Proposal Due Date.</p>
4.5	<p>Best Value Selection and Negotiation</p> <p>MMPRC may select the response(s) which demonstrates the best overall value, including proposed alternatives that will achieve the goals of MMPRC. MMPRC and a selected Tenderer may negotiate a change in element of contract performance or cost identified in the original proposal or the selected Tenderer’s response which results in lower costs or more cost effective or better value than was presented in the selected Tenderer’s original value.</p>
5.	<p>Disqualification</p>

5.1	<p>MMPRC shall have absolute discretion to disqualify any Proposal made by a Respondent on any one or more of the following grounds;</p> <ul style="list-style-type: none"> a) The Proposal is not accompanied by documents required to be submitted (as detailed in clause 3.5) in accordance with this RFP; b) If the Respondent submits incorrect/ inaccurate/ misleading information or conceals/suppresses any relevant information c) Where the Respondent seeks to modify the Proposal after Proposal Due Date without the consent of MMPRC d) Any Proposal that is received after the Proposal Due Date e) Pending, active, or previous legal action by/ against a Tenderer /Respondent that may prevent its participation in the Tender Process or prevent it from fulfilling its respective obligations as specified and/ or as required in/under this RFP and the Agreement; and/ or f) If the Respondent is in breach of any of its material contractual obligations at any of its previous contracts with the Government of Maldives or MMPRC
6.	Evaluation
6.1	<p>The tender evaluations will be carried out as per the evaluation criteria stated under Section 2 of this document. No other evaluation criteria or methodologies shall be permitted.</p>
6.2	<p>To assist in the examination, evaluation, and comparison of Bids, MMPRC may, at its discretion, ask any Tenderer for clarification of its Bid. The request for clarification and the response shall be in writing, but no change in the price or substance of the Bid shall be sought, offered, or permitted except as required to confirm the correction of arithmetic errors discovered by MMPRC in the evaluation of the Bids.</p>
6.3	<p>From the Bid Due Date until the issue of the Letter of Award, if any Tenderer wishes to contact MMPRC on any matter related to the Bid or the Bid Process, it should be done in writing.</p>

6.4	Any effort on the part of the Tenderers to influence MMPRC in the examination, evaluation, ranking of Bids may result in the rejection of the respective Tenderer's Bid.
7.	Tender Security and Performance Guaranty (Not applicable)
8.	Advance Payment - applicable as per procedure Advance Payment Guaranty - as per procedure
9.	Award of Contract
9.1	MMPRC will issue the Letter of Award to the Respondent whose Proposal has been determined to be responsive and has the highest score (the "Selected Respondent").
9.2	The Letter of Award will be issued to the Selected Respondent or posted to the Selected Respondent's address, or a scanned version of the Letter of Award shall be sent via e-mail at the address given in the Proposal and such handing or posting or e-mail shall be deemed good service of such a notice.
9.3	If the Selected Respondent fails to sign the Agreement within the period prescribed in the Letter of Award, MMPRC shall have the right at its absolute discretion to select the Proposal with the highest score among the remaining responsive Respondents or annul the Tender Process.
9.4	MMPRC reserves the right to annul the Tender Process and reject all Proposals, at any time prior to signing of the Agreement, without thereby incurring any liability to the Respondents, or any obligation to inform the Respondents of the grounds for MMPRC's action.
9.5	Upon MMPRC's request, the Selected Respondent shall provide any component missing from the proposed design as per the specification and scope provided by MMPRC in Section 3 of this RFP, without any additional cost.
10.	Payment Terms
10.1	As consideration for the design and construction of the Maldives Stand at the FESPO 2023 the Selected Respondent/Contractor shall be compensated in the manner provided below;

	<ul style="list-style-type: none"> - The amount in Dollar (\$) equivalent to 15% of the Total Price quoted shall be transferred by MMPRC to the Selected Respondent/Contractor, upon signing of this Agreement, within 30 working days up on submission of the invoice and, - The amount in Dollar (\$) equivalent to 35% of the Total Price quoted shall be transferred by MMPRC to the Selected Respondent/Contractor, within 30 working days after the commencement of the work and upon submission of the invoice and, - Remaining 50% of the Total Price quoted shall be transferred by MMPRC to the Selected Respondent/Contractor, after the end of the fair within 30 working days and up on submission of the final invoice, - Any payment made on behalf MMPRC will be reimbursed once the invoice along with supporting documents are received.
11	Penalty & Contract Termination
11.1	<p>Penalty: MMPRC shall have the right to withhold any payment of the Contract Price, if the Selected party fails to deliver any Works in accordance with the terms of the Agreement.</p>
11.2	<p>Contract Termination: If the Selected Party fails to carry out any obligation under the Agreement, MMPRC may by notice require the Contractor to make good the failure and to remedy it within a specified reasonable time.</p>

Section 2 - Evaluation Criteria

Area	Details	Marks
Contract Price	The Tenderer proposing the lowest “Contract Price” shall receive a maximum mark of Forty (40), and for remaining proposals marks will be allocated on pro rata basis.	40
Stand Design- Attractiveness	<p>The marks for the attractiveness of the stand design will be given considering the below mentioned. The design which full fill the requirements will receive the highest marks.</p> <p>a) Attractiveness of the overall design:</p> <p>b) Reflection of the destination in design: Beauty, authenticity and usage of attractive images to show the USPs / experiences of Maldives.</p> <p>c) Creativity: The design should showcase the Maldives product in a creative manner using the latest technologies without foregoing or hindering any requirement set out in the RFP.</p>	30
Stand Design- Requirements	<p>The marks for the requirements of the stand design will be given considering the below mentioned. The design which full fill the requirements will receive the highest marks.</p> <p>a) Meeting all the requirements mentioned in the scope and specification in Section 3</p> <p>b) Photo Backdrop: A wall or prominent area of the Stand that can be used as a photo backdrop. Should be a visually eye-catching backdrop which can be shared on social media. It should also be visible from outside and easily accessible from the main counter to the visitors passing by. Maldives branding should be visible in this area. The purpose of this area is to attract visitors to Maldives Stand and take a</p>	15

	<p>picture and participate in the promotional social media campaign by sharing these pictures on social media.</p> <p>c) Map of Maldives: There should be a map of Maldives displayed in the stand at a prominent location which is easily accessible to visitors.</p> <p>d) Space Utilization: All the requirement set forth in the Scope of Work should be fulfilled in an orderly manner and logically practical format.</p>	
Past Experience	<p>Marks for experience with related works will be given as mentioned below.</p> <p>a) 3 letters: 10 marks</p> <p>b) 2 letters: 6 marks</p> <p>c) 1 letter: 3 marks</p> <p>If the Tenderer/respondent has worked with MMPRC and if the performance is found to be unsatisfactory, then marks will be deducted.</p> <p>Past experience letter will only be accepted as complete if the supporting images and details are provided.</p>	10
Company Profile	<p>Marks will be given considering the below mentioned points;</p> <p>a) The organizational structure</p> <p>b) Proposed team for this project</p> <p>c) Number of years in operation</p> <p>d) Services offered by the company</p>	5
	TOTAL	100

Section 3 - Scope of Work & Specifications	
1	SCOPE OF WORK
	<p>1.1. Main scope of the project is to design a functional Stand for Maldives according to MMPRC's requirements (the "Stand"), and Construction of the Stand in accordance with the Regulations set by FESPO 2023 Fair organizers (Refer to organizer's official website (https://www.fespo.ch/fes-de.aspx)). It is the responsibility of the bidder to take all preventive measures set out by the fair organisers with regard to COVID19 (if any)</p> <p>1.2. In addition, the scope of the works shall include;</p> <p>1.2.1. The construction of the Stand to agreed design proposal, and the construction of the Stand at the site provided to MMPRC by the FESPO Fair organizers for the year 2023;</p> <p>1.2.2. Complete construction and handover of the finished stand 24 hours before the opening time of the fair, allowing sufficient time for MMPRC officials to arrange materials and finalise the stand. In addition, the stand should be cleaned, and garbage should be cleared from the stand area at the time of handing over the finished stand and it should be ready for immediate usage.</p> <p>1.2.3. The process of disassembling the stand should start as soon as the stand is handed over by MMPRC at the end of the Fair. This should be carried out according to the organiser's guidelines.</p> <p>1.3. Interested parties need to submit a design and the estimated cost to construct the Maldives stand at FESPO 2023.</p>
2	CONCEPT FOR THE DESIGN PROPOSED BY THE BIDDER/RESPONDENT
	<p>2.1 FESPO, is Switzerland's largest tourism platform dedicated to the enhanced travel experience industry.</p> <p>2.2 The Stand concept and design should be presented in a contemporary design to attractively showcase the country's unique tourism product, USPs, whilst at the same time inspired by the element of luxury and usage of authentic Maldivian designs representing the unique features of the island destination. The proposed design should be as per the regulations set out by the fair organisers in adhering to the safety and preventive measures.</p> <p>2.3 <u>The concept and design should strongly address the following points:</u></p> <p>2.3.1 Attractiveness of the overall design</p> <p>2.3.2 Reflection of the destination in design/ Beauty, authenticity, and usage of attractive images to show the USPs / experiences of Maldives.</p> <p>2.3.3 Creativity - The design should showcase the Maldives product in a creative manner using the latest technologies without hindering any requirement set out in the RFP.</p> <p>2.3.4 Meeting all the requirements mentioned in the Scope and Specifications in <u>Appendix A</u></p> <p>2.3.5 Photo Backdrop - A wall or prominent area of the Stand that can be used as a photo backdrop. Should be a visually eye-catching backdrop which is</p>

	<p>“instagrammable”. It should also be visible from outside and easily accessible from the main counter to the visitors passing by. Maldives branding should be visible in this area. The purpose of this area is to attract visitors to Maldives Stand and take a picture and participate in the promotional and social media activities by sharing these pictures on social media.</p> <p>2.3.6 Map of Maldives - There should be a map of Maldives displayed in the Stand at a prominent location easily accessible to visitors.</p> <p>2.3.7 Space Utilization - All the requirements set forth in the Scope of Work should be fulfilled in an orderly, logically practical manner at the same time consideration should be given to safety & preventive measures set out by the fair organiser. The stand should be made in a way that prevents visitor bottlenecks in the stand.</p>
3	STAND REQUIREMENTS
	<p>Stand should have lockable counters, storage and a reception desk and should be arranged in a logical and practical manner considering the new social distancing rules implemented by the fair organiser. The furniture and decorative items used should be simple and elegant to bring out the luxury image of the destination. The measurements given in specific areas should meet the criteria. Items with no specific measurements are left for the designer's choice. All furniture/equipment requirements are stated under each item.</p> <p>1.1. <u>Counters</u> There must be separate lockable counters around the Stand with the storing capacity for brochures and bags. However, there should be easy access into the Stand from all the sides. There should be a Minimum 12 counters that aligns with the COVID-19 safety guidelines provided by the fair organiser. Counters sizes should be as follows;</p> <ul style="list-style-type: none"> ● The counter dimensions should be a 600mmX450mm. ● The Space between two counters should be 350mm. ● The counters should have a height of 1075mm from the floor. ● The height of counter dividers should be 152mm ● Should there be any structures/walls behind the counter then there should be a gap of 1219mm. ● Should display co-exhibitor names on the front of the counter. ● Should include counter stools. ● Should include universal electric plug points in each counter. ● Should include lockable drawers in each counter. Individual keys for each lock at the counter must be provided. <p>Please refer to section 7 for measurement details.</p> <p>1.2. <u>Information Counter</u></p> <ul style="list-style-type: none"> ● One information counter with shelves and lockable drawers to store promotional materials should be included in the design. ● Furniture: 2 stools for the representatives.. ● Should include universal electric plug points. <p>1.3. <u>Storage Room</u></p> <ul style="list-style-type: none"> ● A lockable storage should be within the Stand to store promotional materials, should accommodate boxes and hand carry trolley luggage.

- Should include a lockable cupboard to store valuable materials.
- Should include Racks to keep brochures, bags and other promotional materials. The racks should be able to hold an approximate weight of not less than 120kg.
- Should include universal electric plug points.

1.4. **Meeting Area**

- 3.4.1 There should be a maximum number of meeting tables that aligns with the COVID-19 safety guidelines provided by the fair organiser.
- 3.4.2 There should be 4 chairs per table.
- 3.4.3 Should include universal electric plug points for each table.

Please refer to section 7 for measurement details.

1.5. **Displays**

- 1.5.1. LED Screen with USB port should be on display facing the main entrance of the stand. LED Screen should be of a size which can easily be accommodated and suitable to the stand size.
- 1.5.2. Should provide adequate sound.
- 1.5.3. Should be able to utilise the main screen for presentations and to display relevant videos and graphical content throughout the fair days.
- 1.5.4. The display area should be adjustable in accordance with 3.5.2.
- 1.5.5. In addition to the above, relevant photos, decorative materials and equipment can be used in the design to enhance the quality of the stand.
- 1.5.6. Participation list should be displayed in vertical format in a plasma screen of 50” in a prominent location, ideally next to the main information counter.

1.6. **Stand Name**

- 1.6.1. Name of the Stand should be “Maldives” with the logo (Annex D) which should be visible from all sides. Maximum visibility of the stand name should be provided.
- 1.6.2. A hanging banner with the Maldives logo (As per Appendix D) visible from all the sides of the stand needs to be placed above the stand at the maximum height.
- 1.6.3. Maldives branding (As per Appendix D) should be visible at prominent locations within the stand incorporated to the overall stand design.

1.7. **Additional Services**

- 1.7.1. Should provide a coffee machine (with sugar, milk, coffee capsule) with at least 100 paper cups. (No single use plastic)
- 1.7.2. Should provide water bottles for the fair duration. (No single use plastic)
- 1.7.3. Should provide daily cleaning and garbage disposal services for the fair duration.
- 1.7.4. Should provide hand sanitizers at the stand

	<p>1.8. <u>Spinning Wheel</u></p> <p>1.8.1. A spinning wheel to be used for activities, this will include the name of the promotional materials which will be distributed</p> <p>1.8.2. It should be stable and lightweight to move around easily</p> <p>1.8.3. Should be an attractive design that compliments the destination image.</p> <p>1.8.4. Content will be shared with the awarded party</p>
4	ADDITIONAL CONDITIONS AND REQUIREMENTS
	<p>1.9. The design should be in conformity to the Maldives Stand concept and Design Requirement and Stand Building Regulations set by FESPO 2023 fair organizers (Refer to organizer's official website)</p> <p>1.10. It is the duty of the Selected Party to meet specific requirements of the FESPO 2023, so that the Stand receives due recognition from the organizer and public.</p> <p>1.11. Additional services such as electricity, rigging, internet connections etc needs to be ordered by the Selected Party (Contractor) on behalf of MMPRC (with prior approval) and billed to MMPRC.</p> <p>1.12. All documentations necessary for Stand design approval should be submitted by the Selected Party before the deadline specified by the FESPO 2023 organisers.</p> <p>1.13. All the graphics shall be provided by MMPRC</p> <p>1.14. Complete construction and handover of the finished stand 24 hours before the opening time of the fair.</p> <p>1.15. Any cost which may arise outside of the above quotation shall be borne by the Selected Party.</p> <p>1.16. Sufficient amount of lighting (where required) should be used when designing the Stand</p> <p>1.17. Additional covid-19 protection gears at the stand.</p> <p>1.18. The fair organisers only allow pre-fabricated design</p> <p>1.19. The price quoted by the bidder should include all the aforementioned requirements. MMPRC should not be borne to pay any additional charge.</p>

Section 4 - COVER LETTER

The CEO & Managing Director,
 Maldives Marketing and Public Relations Corporation
 H. Zonaria, 2nd Floor, Boduthakurufaanu Magu, Male'
 Republic of Maldives

Dear Sir,

Sub: Proposal to design and construct the Maldives Stand at FESPO 2023.

Having examined all the information provided, we the undersigned offer to design and construct the Maldives Stand at FESPO 2023 as per the requirements of the RFP (the "Works") as set out in this Proposal.

We agree to undertake and complete the Works for a total sum of Dollars (\$) (In words) Dollars (\$) (In numbers). (The "Contract Price") inclusive of all applicable taxes (including tax). A summary of the annual breakdown of the Contract Price is provided below;

Year	Price excluding Tax (\$)	Tax (\$)	Total Price (\$)
FESPO 2023			
Added options should be included in this table			
Contract Price(\$)			

We undertake, if our Proposal is accepted, to complete the Works within the deadlines and as per the specifications provided by MMPRC. We have examined the RFP and have no reservations to the RFP Documents, including Addenda issued.

We are not insolvent, in receivership, bankrupt or being wound up. Our affairs are not being administered by a court or a judicial officer and our business activities are not being suspended and not the subject of legal proceedings for any of the foregoing.

Until a formal agreement is executed with MMPRC, this Proposal, together with written acceptance thereof and MMPRC's notification of award, shall constitute a binding contract if we are selected as the Successful Respondent.

Details of authorized personnel to sign Bid for and on behalf of:

Company/Business Name: _____

Name of the authorized personnel to sign: _____

Signature of the authorized personnel to sign: _____

Stamp of the company/Business: _____

Date: _____

Section 5 - MALDIVES LOGO



Section 6 - FLOOR PLAN

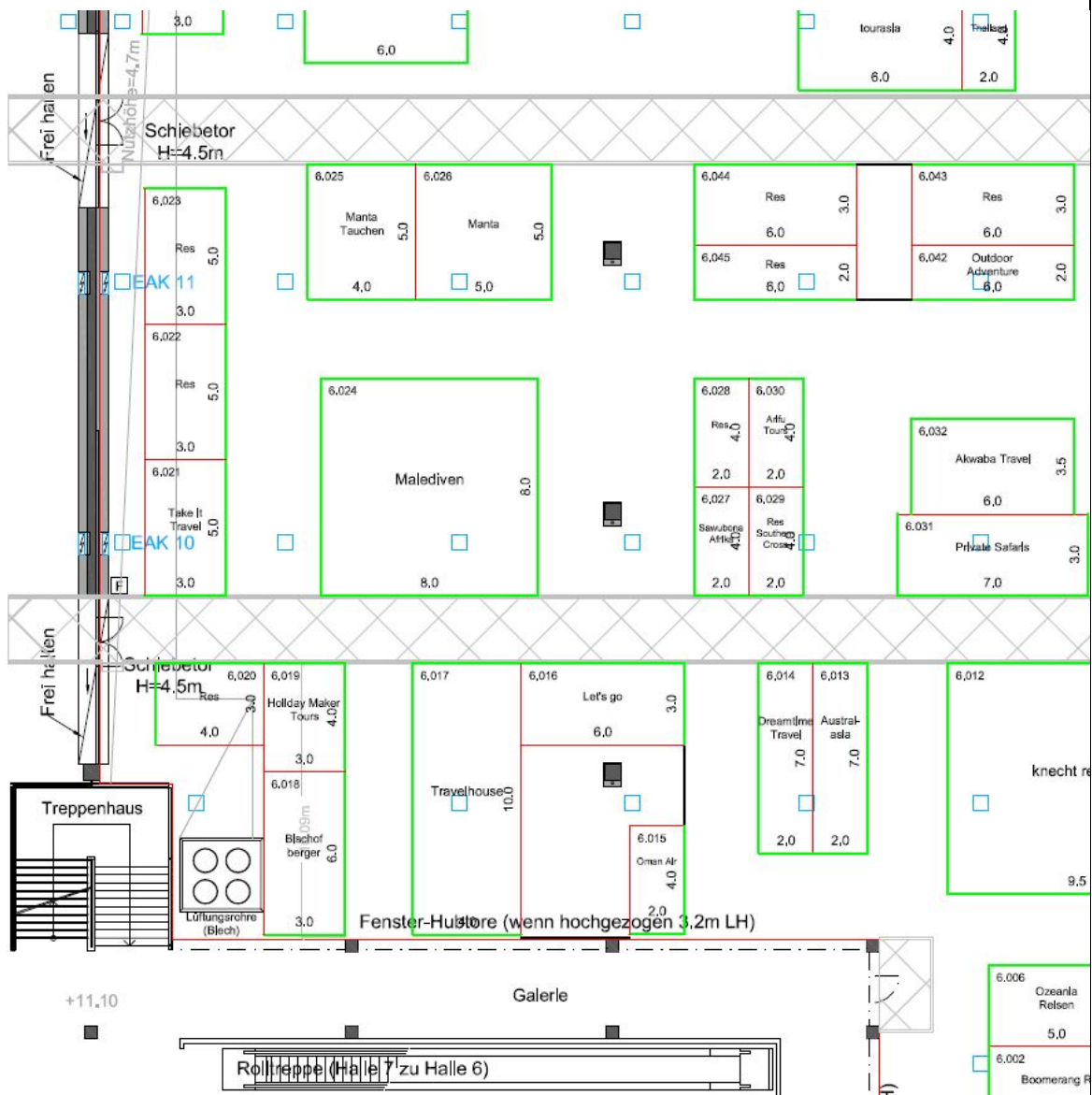

Link for detailed floorplan:

https://aussteller.bernexpo.ch/en/PortalData/52/Resources/x2_fes/dokumente/einteilung/Halle-6.pdf

Section 7 - Measurements

A. Co exhibitors counter sizes

This should be the standard spacing for counters.
This should be given as standard sizes we want for future RFP's

Counters

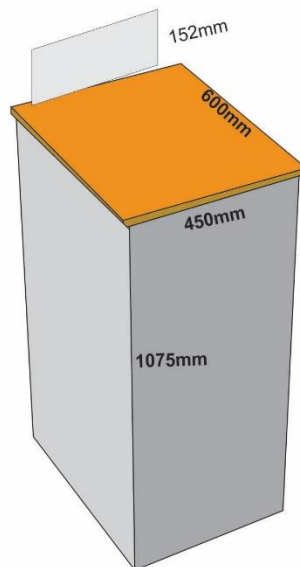
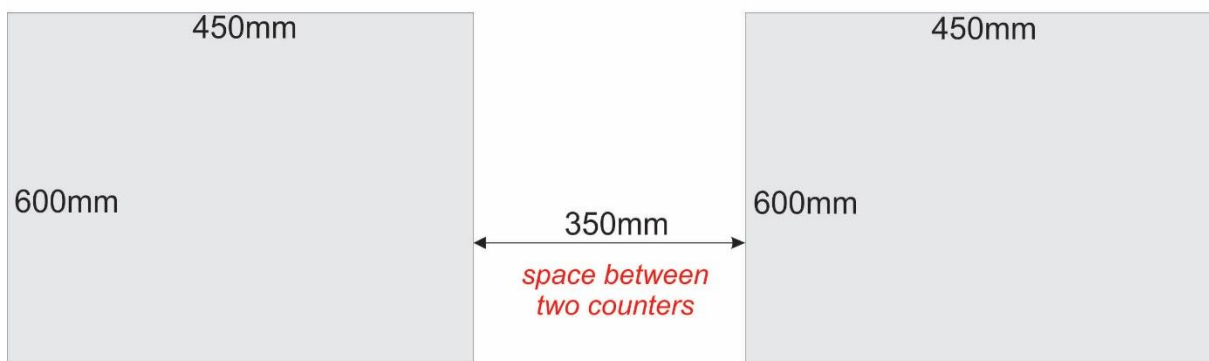

B. B2B Meeting tables

This should be the standard spacing for B2B meeting Tables.

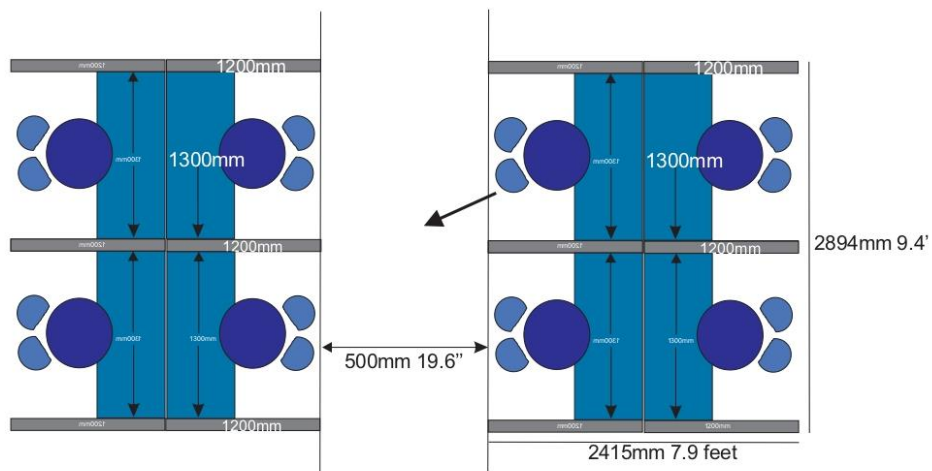
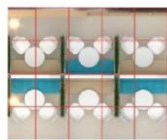

*If the B2b table set up is next to a wall/ railing on a mezzanine floor,
The distance between the chairs and
the wall/railing should not be less than: 1000mm*

